



**B | H**  
TIJUANA



## BUSINESS HUB TIJUANA

Business Hub is a corporate center, strategically designed to meet all of your executive's needs.

With Class A spaces and first-level amenities, such as:

- Corporate offices
- Business Center
- Business Lunch
- Business Terrace
- Commercial area

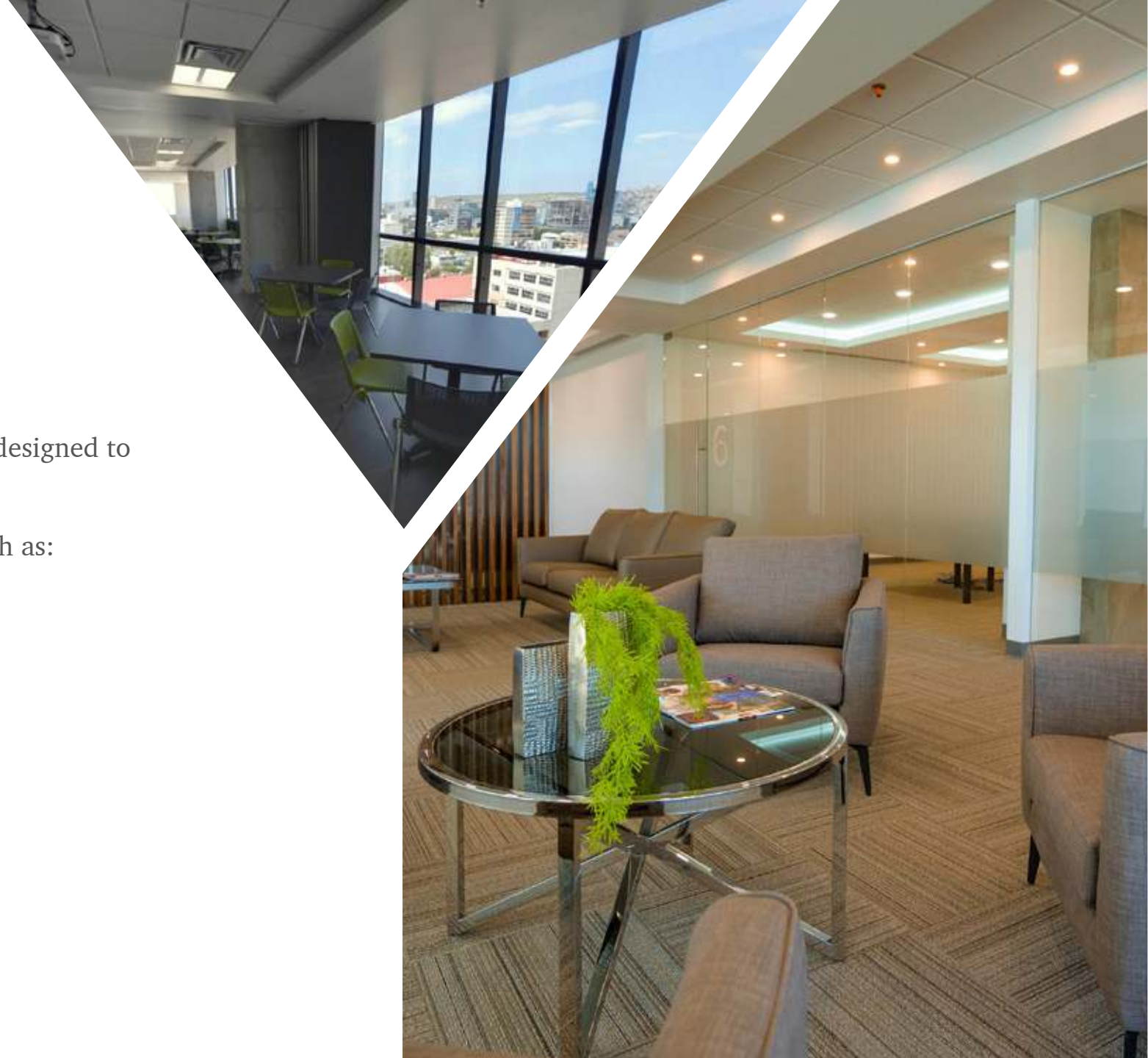

**EXCELLENT LOCATION**  
**AT TIJUANA'S GOLDEN ZONE**

10485, Gustavo Salinas Blvd.  
Aviación. Tijuana, B.C.



# BUSINESS HUB TIJUANA

## LOCATION

- Excellent and quick access through any point from the city.
- Wide streets with public transportation access.
- Amazing 360° views.
- Restaurants, hotels, malls, banks, and more within a short distance.
- Distance from B.H. with:

### **SAN YSIDRO BORDER**

2.85 mi

### **CALIENTE STADIUM**

1.42 mi

### **AIRPORT**

3.41 mi

### **OTAY BORDER**

7.76 mi

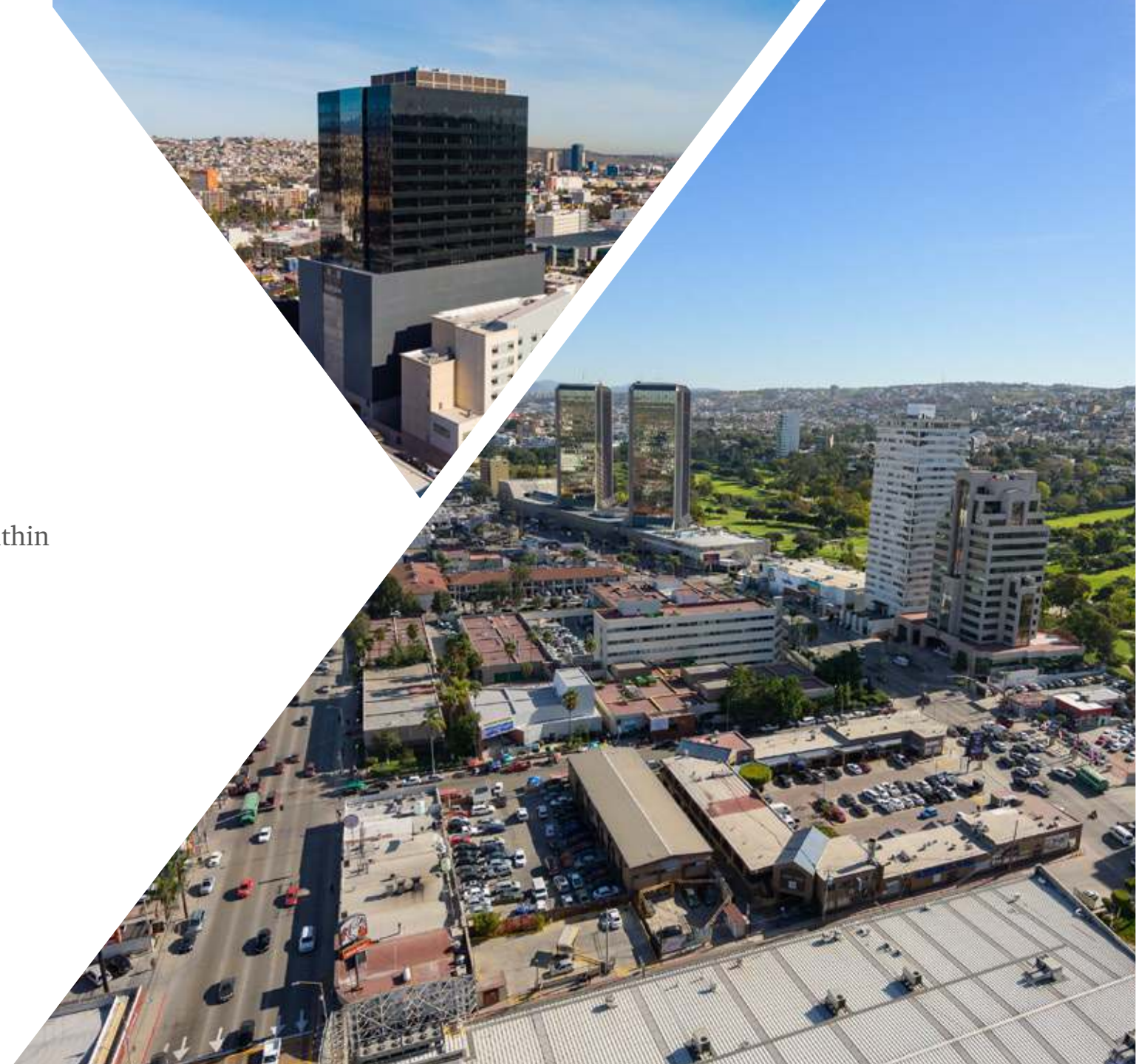

## BUSINESS HUB TIJUANA OFFICES

- 01 21 stories: 9 parking levels above ground, 1 ground level, 11 levels for office spaces.
- 02 17,915 square meters of total leasing space
  - Office spaces from 80 m<sup>2</sup> (1,722 SF)
  - 1,670m<sup>2</sup> Floorplates (17,975 SF)
- 03 Parking spaces for visitors.
- 04 Parking: 1 parking spot for every 22 SQF of leased office space (15% designated spaces, 85% free pool parking lot).
- 05 Storage areas available for lease, different dimensions.

# BUSINESS HUB TIJUANA

## AN INSPIRING ENVIRONMENT

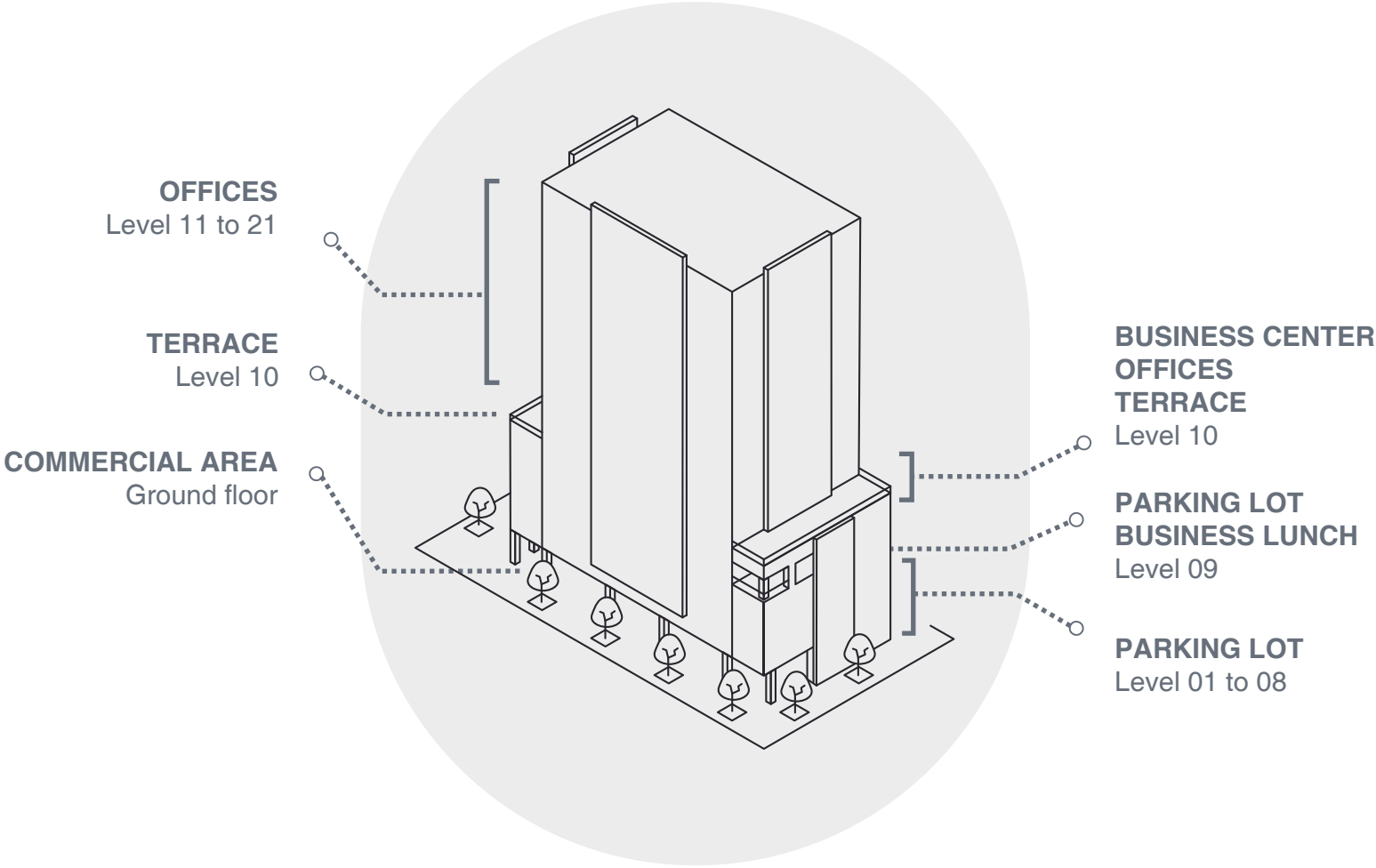



**LOBBY/GROUND LEVEL**



MEETING ROOM



MEETING ROOM



PARKING LOT



HALL AREA



# BUSINESS CENTER



# BUSINESS LUNCH

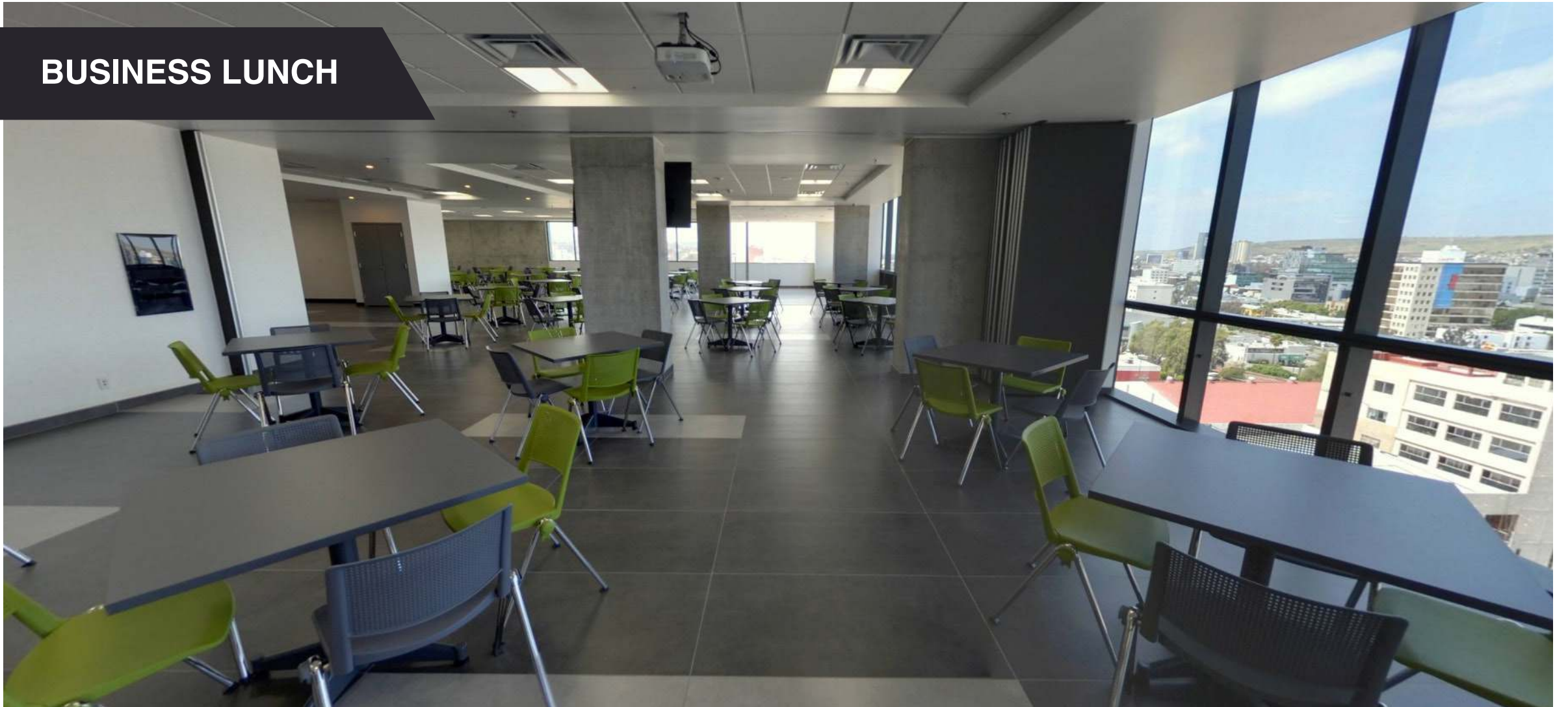

IMAGE FOR ILLUSTRATIVE PURPOSES ONLY.



**BUSINESS LUNCH**



HYATT PLACE (BLVD. AGUA CALIENTE)



AZCARATE

ARMANDO PANIAGUA

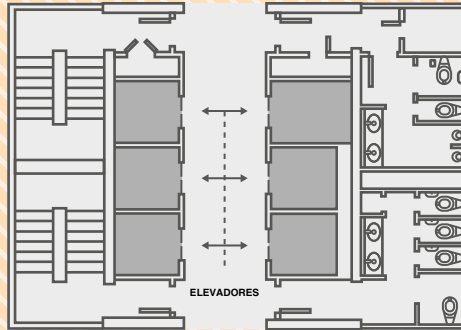

**FLOOR PLATE**  
17,975.73 SF

BULEVAR SALINAS

HYATT PLACE (BLVD. AGUA CALIENTE)

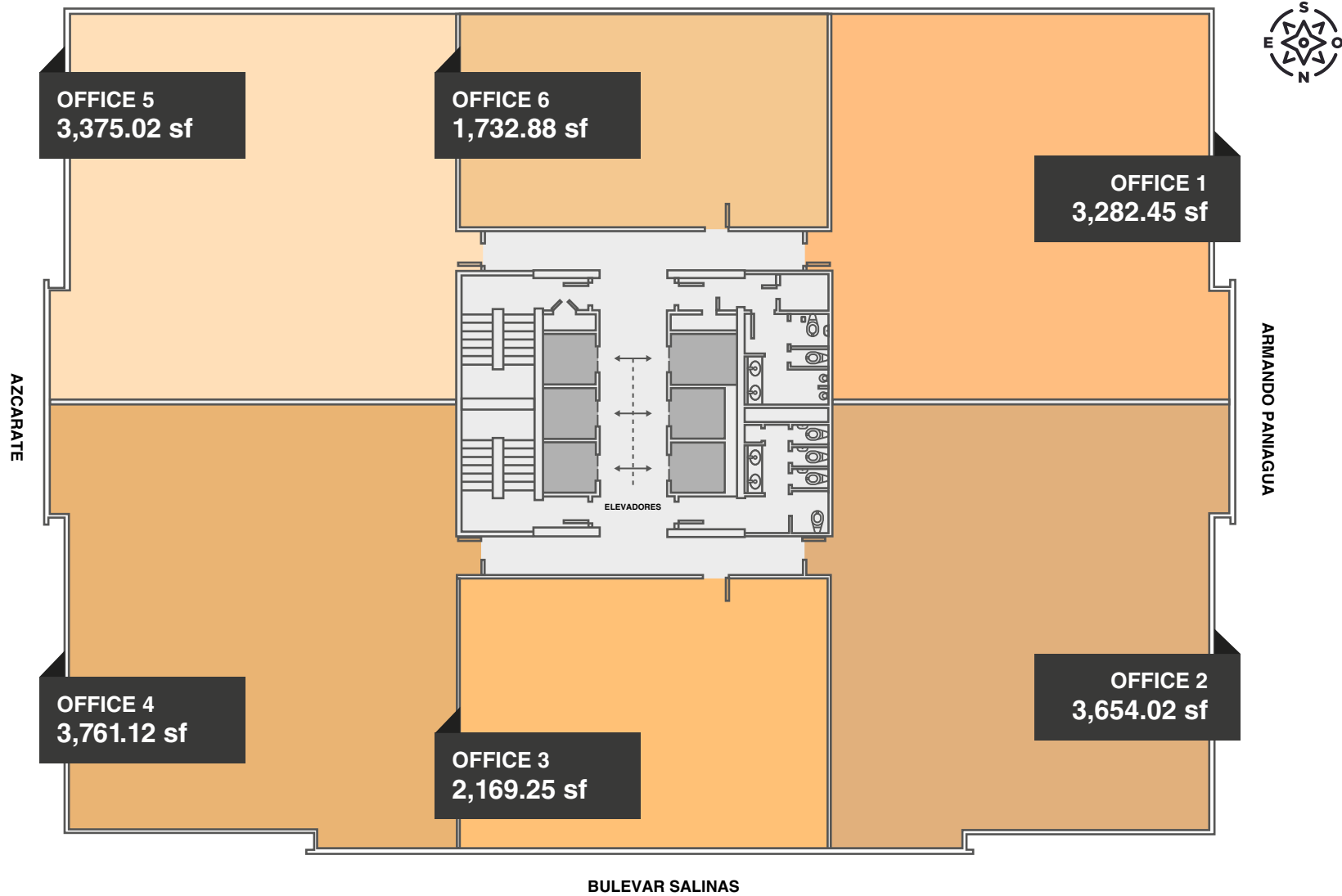

## OFFICE SPACES

Spaces can be arranged according to client's requirements.

HYATT PLACE (BLVD. AGUA CALIENTE)

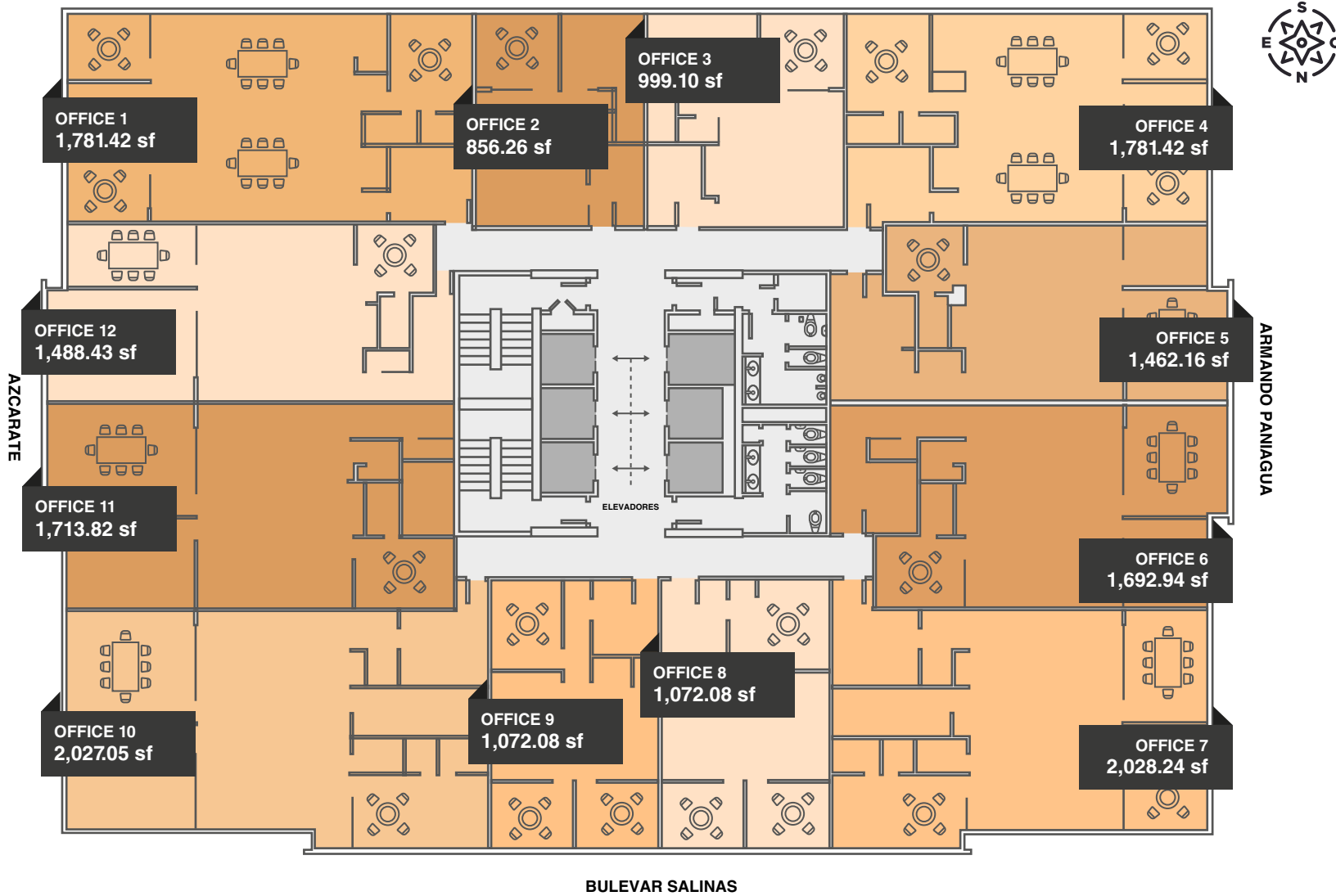

**FLOOR PLATE LEVEL 11**  
Spaces from 861.11 SF

B | H

TIJUANA

FEEL FREE TO CONTACT US REGARDING  
ANY QUESTIONS OR COMMENTS.

**David Moreno**

[david.moreno@bhtijuana.com](mailto:david.moreno@bhtijuana.com)

**Ing. Francisco Villaseñor G.**

[fvillasenor@plate.mx](mailto:fvillasenor@plate.mx)

**Telephone**

(664) 423-5555